

de	Installationsanleitung	Raumgerät
en	Installation Instructions	Room Unit
fr	Instructions d'installation	Appareil d'ambiance
it	Istruzioni di montaggio	Unità ambiente
nl	Installatie-aanwijzing	Ruimte-apparaat

QAW70

de Installationsanleitung

Montageort

Festlegen des Montageortes

- In trockenem Raum (bei Raumeinfluss in Referenzraum), z.B. im Wohnzimmer, Büro etc.
- Thermostatventile im Referenzraum voll öffnen
- Einbaumöglichkeiten:
Wandmontage (Innenwand, Schaltschrankfront etc.)

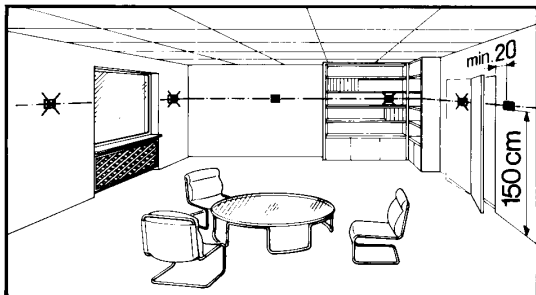

- Zulässige Umgebungstemperatur ist 0...35 °C

Elektrische Installation

- Örtliche Vorschriften für Elektroinstallationen sind zu beachten
- Die Verbindung zum Regler und zum externen Fühler/Kontakt führt Kleinspannung
- Fühlerleitungen dürfen nicht parallel mit Netzleitungen geführt werden

Zulässige Leitungslängen

- Zum Regler:
Cu-Kabel 0,25 mm² max. 25 m
Cu-Kabel ab 0,5 mm² max. 50 m
- Zum externen Kontakt oder Fühler:
Cu-Kabel 0,6 mm Ø max. 20 m
Cu-Kabel ab 1,0 mm² max. 50 m

Montieren und Verdrahten des Sockels

Montage: siehe Geräteverpackung

Verdrahtung:

- Mit einem externen Fühler (QAW44)

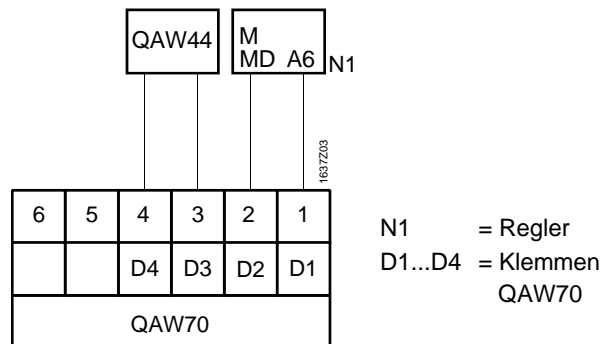

- Mit einem externen Kontakt (Telefonfernschalter)

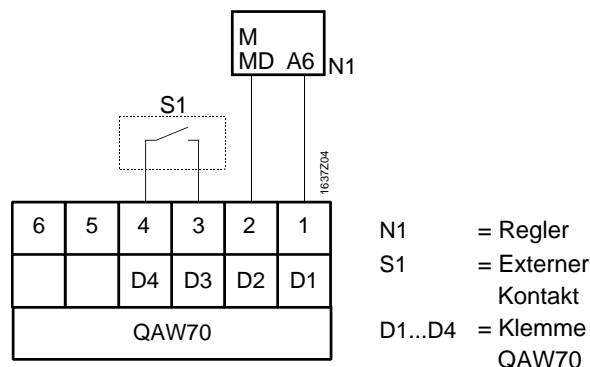

Inbetriebnahme

Vorbereitende Kontrollen

1. Verdrahtung nach dem Anlageschaltplan prüfen
2. Betriebsspannung am Regler einschalten. Im Anzeigefeld des Raumgerätes muss eine Anzeige erscheinen. Wenn nicht, so sind folgende Ursachen wahrscheinlich:
 - Regler hat keine Netzspannung
 - Verdrahtung zum Regler ist unterbrochen
 - Raumgerät ist nicht korrekt im Sockel eingeschnappt



Grundsätzliches zur Bedienung





Siehe Bedienungsanleitung







Einstellungen für den Endbenutzer

Siehe Bedienungsanleitung

Einstellung auf der Ebene «Heizungsfachmann»

Tasten  und  gleichzeitig drücken, bis die Bedienzeile **51** angezeigt wird. Dadurch ist die Einstellebene "Fachmann" für Einstellungen freigegeben.

Danach können mit den  und  Tasten die einzelnen Bedienzeilen angewählt und die Werte mit den  oder  Tasten eingestellt werden.

Zeile	Funktion, Anzeige	ab Werk	Bereich	Eingabe	Erläuterungen, Hinweise, Tips
51	Geräteadresse	1	1...10	Doppelpunkt zeigt zusätzlich den Status der Kommunikation an: <ul style="list-style-type: none"> Doppelpunkt blinkt regelmässig = Kommunikation läuft Doppelpunkt nicht vorhanden oder blinkt nicht = für Kommunikation bereit
52	Geräteidentifikation	Anzeigefunktion			xx yyyy xx = Geräteidentifikationsnummer yyyy = SW-Versionsnummer
53	Programmiersperre Bedienzeilen	0	0 / 1	0 = keine Bediensperre 1 = Alle Bedienzeilen sind gegen Verstellung gesperrt. Temporäre Aufhebung der Bediensperre: Tasten  und  so lange drücken bis "     " angezeigt wird. Verstellungen können nun vorgenommen werden, bis der Deckel wieder geschlossen wird. Dauerhafte Aufhebung der Bediensperre: Bediensperre zuerst temporär aufheben. Anschliessend die Bedienzeile 53 auf 0 stellen.
55	Funktion Eingang (D3/D4)	1	1 / 2 / 3 / RL	1 = externer Fühler: In der Anzeige wird zusätzlich seine Temperatur angezeigt. (--- = kein Fühler angeschlossen, Funktion inaktiv). 2 = externer Kontakt: Umschaltung auf reduzierte Temperatur. In der Anzeige wird zusätzlich der aktuelle Kontaktzustand angezeigt (000 = Kontakt zu, --- = Kontakt offen). 3 = externer Kontakt: Umschaltung auf Frostschutztemperatur. Das Brauchwasser wird zudem ausgeschaltet. In der Anzeige wird zusätzlich der aktuelle Kontaktzustand angezeigt (000 = Kontakt zu, --- = Kontakt offen). RL = unerlaubte Einstellung
56	Wirksinn externer Kontakt (S1)	000	000 / ---	000 = die auf der Bedienzeile 55 eingestellte Funktion (2 oder 3) wirkt bei geschlossenem Kontakt --- = die auf der Bedienzeile 55 eingestellte Funktion (2 oder 3) wirkt bei offenem Kontakt
57	Einfluss externer Raumfühler (QAW44)	50 %	0...100%	0 % = externer Fühler wirkt zu 0 % (interner Fühler wirkt zu 100 %) 50 % = externer Fühler wirkt zu 50 % (interner Fühler wirkt zu 50 %) 100 % = externer Fühler wirkt zu 100 % (interner Fühler wirkt zu 0 %)
58	Anzeige der Sollwerte	AbS	AbS / rEL	Die Raumtemperatursollwerte können absolut oder relativ eingegeben und angezeigt werden. AbS = absolut; z.B. 20.5 °C rEL = relativ; z.B. + 0.5 °C

Abschließende Arbeiten

1. Einstellungen in diese Anleitung eintragen. Anleitung an einem geeigneten Ort aufbewahren
2. Bedienungsanleitung ins Gerät einschieben

Maßbild

Siehe Geräteverpackung

Place of installation

Choosing the place of installation

- In a dry room (in the case of room influence in the reference room), e.g. in the living room, office, etc.
- Thermostatic radiator valves in the reference room must be fully opened
- Mounting choices:
Wall mounting (inner wall, control panel front, etc.)

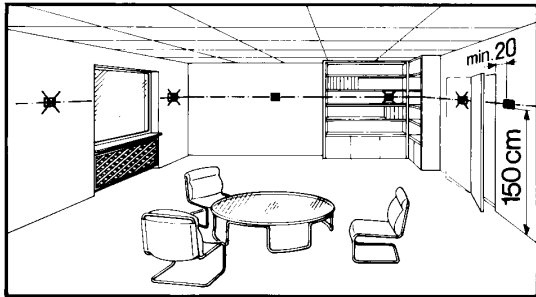

- Permissible ambient temperature: 0...35 °C

Electrical installation

- The local regulations for electrical installations must be complied with
- The cables from the room unit to the controller and the external sensor / switch carry low voltage
- Sensor cables may not be run parallel to mains carrying cable

Permissible cable lengths

- To the controller:
Copper cable 0.25 mm² max. 25 m
Copper cable from 0.5 mm² max. 50 m
- To the external switch or sensor:
Copper cable 0.6 mm dia. max. 20 m
Copper cable from 1.0 mm² max. 50 m

Mounting and wiring the base

Mounting: Refer to the packaging

Wiring:

- With external sensor (QAW44)

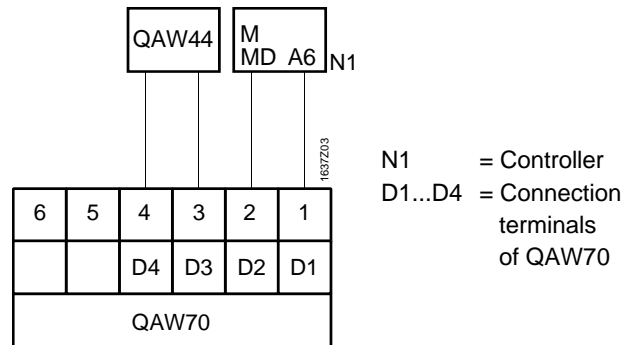

- With external switch (remote telephone switch)

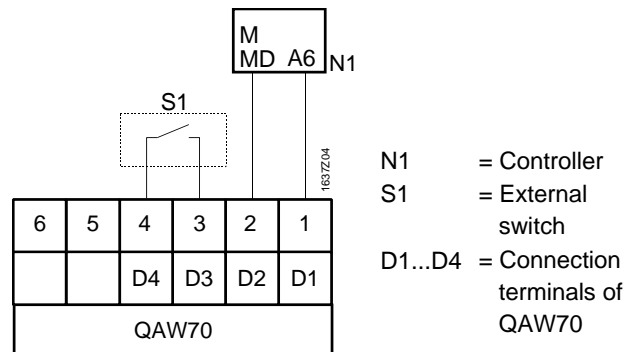

Commissioning

Preparatory checks

1. Check wiring according to the plant connection diagram
2. Switch on the controller's power supply. The room unit's display must show something. If not, the reason will probably be one of the following:
 - Controller without mains voltage
 - Wiring to the controller interrupted
 - Room unit not properly connected to its base



Basic information about operation





Refer to the Operating Instructions









Settings to be made by the end-user

Refer to the Operating Instructions

Settings to be made on the «Heating Engineer's» level

Press buttons  and  simultaneously until operating line **S1** appears. This makes the "Heating Engineer's" level accessible for settings.

Then, the individual operating lines can be selected with the  and  buttons and the values adjusted with the  and  buttons.

Line	Function, display	Default	Range	Setting	Explanations, notes and tips
S1	Device address	1	1...10	Colon also shows the communication status: <ul style="list-style-type: none"> Colon flashes at regular intervals = communication in progress Colon not present or does not flash = ready for communication
S2	Device identification	Display function			xx yyyy xx = device identification number ... yyyy = software version number
S3	Programming lock operating lines	0	0 / 1	0 = no operating lock 1 = All operating lines are locked against readjustment. Temporary cancellation of operating lock: Press buttons  and  until "  
S5	Function of input (D3/D4)	1	1 / 2 / 3 / <i>RL</i>	1 = external sensor: The display also shows the temperature measured with it ( = no sensor connected, function inactive). 2 = external switch: Changeover to reduced temperature; the display also shows the current status of the switch (000 = contact closed,  = contact open). 3 = external switch: Changeover to frost protection temperature; d.h.w. heating is switched off; the display also shows the current status of the switch (000 = contact closed,  = contact open). <i>RL</i> = setting not permitted
S6	Operating action of external switch (S1)	000	000 / 	000 = the function selected on operating line S5 (2 or 3) is active when the contact is closed  = the function selected on operating line S5 (2 or 3) is active when the contact is open
S7	Influence of external room sensor (QAW44)	50 %	0...100%	0 % = influence of external sensor is 0 % (influence of internal sensor is 100 %) 50 % = influence of external sensor is 50 % (influence of internal sensor is 50 %) 100 % = influence of external sensor is 100 % (influence of internal sensor of is 0 %)
S8	Display of setpoints	<i>AbS</i>	<i>AbS</i> / <i>rEL</i>	The room temperature setpoints can be entered and displayed in absolute or relative figures. <i>AbS</i> = absolute; e.g. 20.5 °C <i>rEL</i> = relative; e.g. + 0.5 °C

Final work

1. Enter the settings in these Installation Instructions. Keep Installation Instructions in a safe place
2. Insert Operating Instructions in the unit

Dimensions

Refer to the packaging

fr Instructions d'installation

Lieu de montage

Choisir le lieu de montage

- L'endroit doit être sec (en cas d'influence d'ambiance dans le local de référence), par ex. dans la salle de séjour, le bureau, etc.
- Les robinets thermostatiques du local de référence doivent être entièrement ouverts
- Possibilités de montage:
Montage mural (parois intérieure, façade d'armoire électrique, etc.)

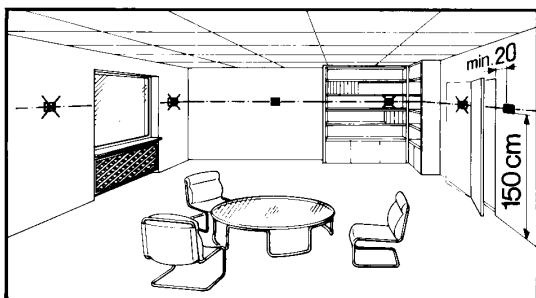

- Température ambiante admissible 0...35 °C

Installation électrique

- Respecter les prescriptions locales d'installation électrique
- La liaison vers le régulateur et la sonde / le contact externes est sous basse tension
- Les câbles de sonde ne doivent pas être posés en parallèle aux câbles d'alimentation secteur

Longueurs de câble admissibles

- Vers le régulateur:
Câble cuivre de 0,25 mm² max. 25 m
Câble cuivre à partir de 0,5 mm² max. 50 m
- Vers le contact ou la sonde externes:
Câble cuivre de Ø 0,6 mm max. 20 m
Câble cuivre à partir de 1,0 mm² max. 50 m

Montage et câblage du socle

Montage: Voir sur l'emballage de l'appareil

Câblage:

- Avec une sonde externe (QAW44)

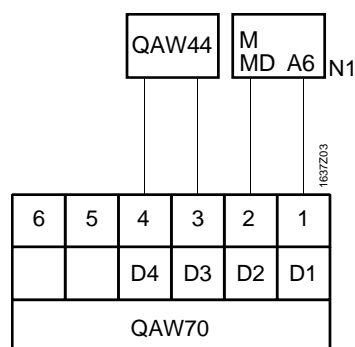

N1 = Régulateur
D1...D4 = Bornes
QAW70

- Avec un contact externe (commutateur téléphonique)

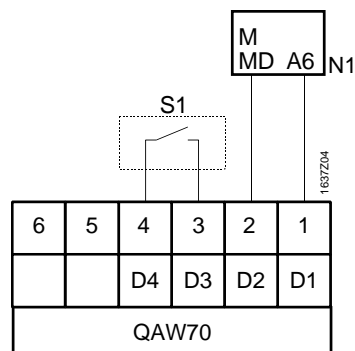

N1 = Régulateur
S1 = Contact
externe
D1...D4 = Bornes
QAW70

Mise en service

Contrôles préalables

1. Contrôler si le câblage correspond au schéma électrique
2. Mettre le régulateur sous tension. L'afficheur de l'appareil d'ambiance est alors activé. S'il n'y a aucun affichage, vérifier les causes probables:
 - le régulateur n'est pas sous tension
 - le câblage vers le régulateur est coupé
 - l'appareil d'ambiance n'est pas correctement enclipsé sur le socle



Principes d'utilisation





Voir mode d'emploi









Réglages pour l'utilisateur final

Voir mode d'emploi

Réglages au niveau «Chauffagiste»

Appuyer simultanément sur les touches  et , jusqu'à obtenir l'affichage de la ligne de commande **51**. Dès lors, le niveau de réglage "Chauffagiste" est accessible pour les réglages.

Ensuite, vous pouvez sélectionner à l'aide des touches  et  les différentes lignes de programmation et régler les valeurs avec les touches  ou .

Ligne	Fonction, affichage	Réglage d'usine	Plage	Entrée	Explications, astuces
51	Adresse d'appareil	1	1...10	Le double point indique également l'état de la communication: <ul style="list-style-type: none"> • Le double point clignote régulièrement = communication en cours • Double point absent ou ne clignote pas = prêt pour la communication
52	Identification de l'appareil	Fonction d'affichage			xx yyyy xx = N° d'identification de l'appareil yyyy = Version du logiciel
53	Blocage de la programmation des lignes de commande	0	0 / 1	0 = pas de blocage 1 = Toutes les lignes de commande sont verrouillées contre les dérèglages. Annulation temporaire du blocage de programmation: Appuyer simultanément sur  et  jusqu'à l'affichage de "   ". Les modifications de réglage sont maintenant possibles jusqu'à fermeture du couvercle. Annulation permanente du blocage de la programmation: Procéder d'abord à une annulation temporaire du blocage de programmation, ensuite mettre la ligne de commande 53 à 0.
55	Fonction entrée (D3/D4)	1	1 / 2 / 3 / RL	1 = sonde externe: Affichage supplémentaire d'une température ( = pas de sonde raccordée, fonction inactive). 2 = contact externe: Commutation sur température réduite. Affichage supplémentaire de l'état actuel du contact (000 = contact fermé,  = contact ouvert). 3 = contact externe: Commutation sur température de protection antigel. De plus, la préparation d'ECS est désactivée. Affichage supplémentaire de l'état actuel du contact (000 = contact fermé,  = contact ouvert). RL = réglage non admis
56	Sens d'action contact externe (S1)	000	000 / 	000 = la fonction réglée à la ligne de commande 55 (2 ou 3) est activée par un contact fermé  = la fonction réglée à la ligne de commande 55 (2 ou 3) est activée par un contact ouvert
57	Influence de la sonde d'ambiance externe (QAW44)	50 %	0...100%	0 % = sonde externe agit à 0 % (sonde interne agit à 100 %) 50 % = sonde externe agit à 50 % (sonde interne agit à 50 %) 100 % = sonde externe agit à 100 % (sonde interne agit à 0 %)
58	Affichage des valeurs de consigne	Ab5	Ab5 / rEL	Les consignes d'ambiance peuvent être entrées et affichées en valeurs absolues ou relatives. Ab5 = valeurs absolues; par ex. 20.5 °C rEL = valeurs relatives; par ex. 0.5 °C

Derniers travaux

1. Reporter les réglages sur cette instruction d'installation. Conserver l'instruction d'installation dans un endroit adéquat
2. Glisser le mode d'emploi dans l'appareil

Encombres

Voir emballage de l'appareil

Posizionamento

Scegliere la posizione

- Ambiente asciutto (nel caso di ambienti con carichi termici diversi scegliere l'ambiente di riferimento), per es. l'ufficio, o il soggiorno
- Le valvole termostatiche devono essere completamente aperte
- Montaggio:
A muro (pannello, fronte quadro, ecc.)

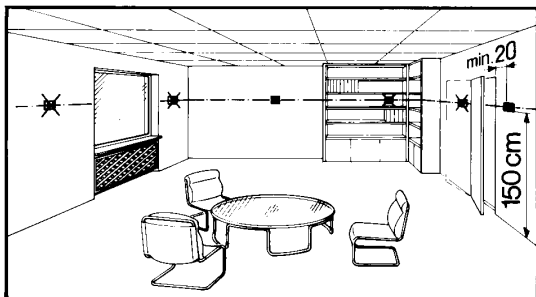

- Temperatura ambiente permessa: 0...35 °C

Installazione elettrica

- Rispettare le leggi e le norme locali
- Il cablaggio dall'unità ambiente e sonde al regolatore sono in bassa tensione
- I cavi delle sonde non devono essere posati paralleli ai cavi di potenza

Lunghezza permessa dei cavi

- Al regolatore:

Cavi in rame	0.25 mm ²	max. 25 m
Cavi in rame da	0.5 mm ²	max. 50 m
- Verso sonde o contatto esterni:

Cavi in rame	0.6 mm dia.	max. 20 m
Cavi in rame da	1.0 mm ²	max. 50 m

Montaggio e connessioni elettriche

Montaggio:

Fare riferimento al disegno sull'imballaggio

Connessioni elettriche:

- Con sonda esterna (QAW44)

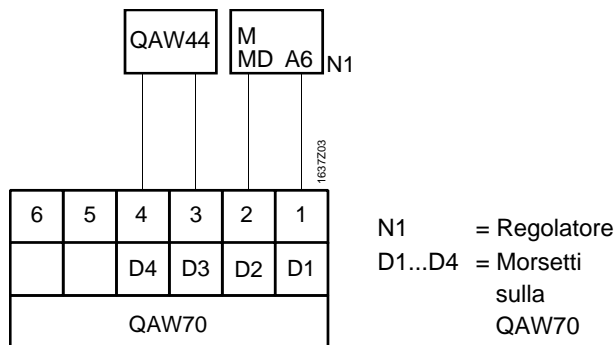

- Con contatto remoto (contatto telefonico remoto)

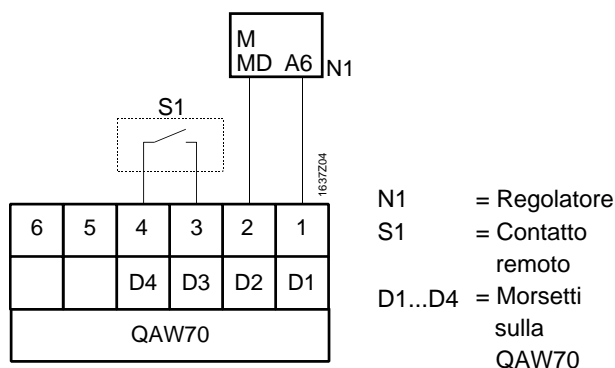

Messa in servizio

Controlli iniziali

1. Verificare i collegamenti elettrici con regolatore e con sonde e contatto remoto
2. Alimentare il regolatore. L'unità ambiente deve accendersi e visualizzare dei dati. Se questo non accade le motivazioni possono essere le seguenti:
 - Regolatore senza la tensione adeguata
 - Connessioni elettriche errate
 - Unità ambiente montata male sulla basetta



Informazioni sulle funzioni di base





Fare riferimento alle istruzioni operative









Settaggi dell'utente

Fare riferimento alle istruzioni operative

Settaggi livello tecnico

Premere i tasti  e  simultaneamente fino a quando non apparirà la linea **S1**. Da questo punto si è entrati nel menù tecnico dove è possibile fare le seguenti modifiche.

Scorrere le linee di programma con i tasti  e  e aggiustare o modificare i valori con i tasti  e .

Linea	Descrizione	Default	Campo	Settaggi	Spiegazioni e suggerimenti
S1	Indirizzo	1	1...10	I due punti mostrano anche lo stato della comunicazione: <ul style="list-style-type: none"> lampeggianti ad intervalli regolari = comunicazione in atto non presenti o non lampeggianti= pronto per comunicare
S2	Identificazione apparecchio	Visualizzazione			xx yyyy xx = numero di identificazione yyyy = versione software
S3	Blocco delle righe	0	0 / 1	0 = nessun blocco 1 = Tutte le righe sono bloccate alla modifica. Temporanea sospensione del blocco: Premere i pulsanti  e  fino a quando appare "   ". Le modifiche possono essere fatte fino a quando viene chiuso lo sportello Esclusione permanente del blocco: Prima, eseguire l'eliminazione temporanea del blocco. Poi impostare in riga S3 lo 0.
S5	Funzione ingresso (D3/D4)	1	1 / 2 / 3 / RL	1 = sonda esterna: Il display mostra il valore della temperatura ( = nessun sensore collegato, funzione inattiva). 2 = contatto esterno: Per commutazione in riduzione; il display mostra lo stato attuale del contatto (000 = contatto chiuso,  = contatto aperto). 3 = contatto esterno: Commutazione alla temperatura di protezione antigelo; a.c.s. riscaldamento in off; il display mostra lo stato attuale del contatto (000 = contatto chiuso,  = contatto aperto). RL = l'impostazione non è permessa
S6	Regime di funzionamento per contatto esterno (S1)	000	000 / 	000 = la funzione è selezionata in riga S5 (2 o 3) è attiva quando il contatto è chiuso  = la funzione è selezionata in riga S5 (2 o 3) è attiva quando il contatto è aperto
S7	Influenza del sensore esterno ambiente (QAW44)	50 %	0...100%	0 % = influenza sonda esterna è 0 % (influenza sonda interna è 100 %) 50 % = influenza sonda esterna è 50 % (influenza sonda interna è 50 %) 100 % = influenza sonda esterna è 100 % (influenza sonda interna è 0 %)
S8	Setpoint visualizzati	AbS	AbS / rEL	Il setpoint temperatura ambiente può essere inserito e visualizzato valore assoluto o relativo. AbS = valore assoluto; per es. 20.5 °C rEL = valore relativo; per es. + 0.5 °C

Controlli finali

1. Scrivere i settaggi effettuati in questo foglio. Conservare questo foglio in un luogo sicuro
2. Inserire le istruzioni operative nell'unità

Dimensioni

Fare riferimento al disegno sull'imballaggio

Montageplaats

Vastleggen van de montageplaats

- In een droge ruimte (met ruimte-invloed in de referentieruimte), b.v. in de woonkamer, het kantoor enz.
- Thermostatische afsluiters in de referentieruimte volledig openzetten
- Inbouwmogelijkheden:
Wandmontage (binnenwand, front schakelkast enz.)

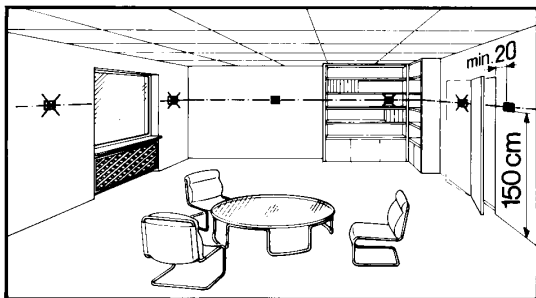

- De toelaatbare omgevingstemperatuur is 0...35 °C

Elektrische installatie

- De plaatselijke voorschriften voor elektrische installaties dienen in acht te worden genomen
- De verbinding met de regelaar en met een extern contact of opnemer voert laagspanning
- De opnemerleidingen mogen niet parallel worden gelegd met netleidingen

Toelaatbare leidinglengten

- Naar de regelaar:
Cu-kabel 0,25 mm² max. 25 m
Cu-kabel vanaf 0.5 mm² max. 50 m
- Naar het externe contact of opnemer:
Cu-kabel 0.6 mm Ø max. 20 m
Cu-kabel vanaf 1.0 mm² max. 50 m

Monteren en bedraden van de sokkel

Montage:

Zie de verpakking van het apparaat

Bedrading:

- Met een externe opnemer (QAW44)

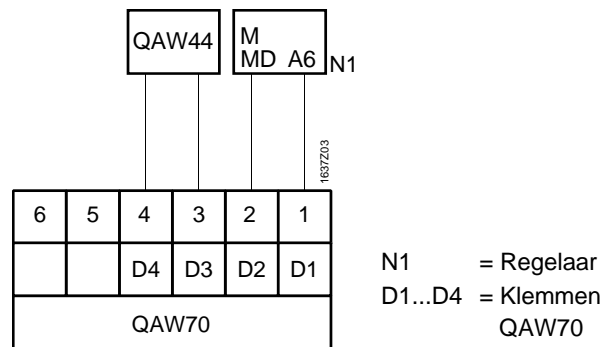

- Met een extern contact (telefoonshakelaar op afstand)

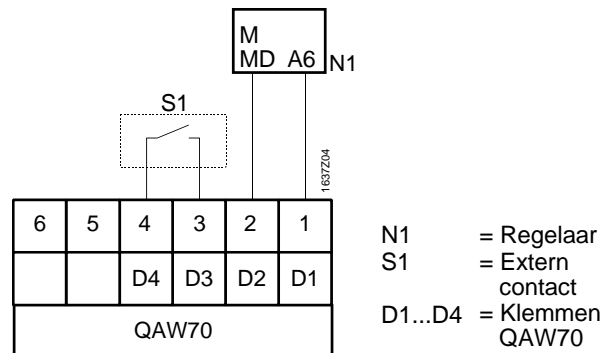

Inbedrijfstelling

Vorbereidende controles

1. Bedrading controleren volgens aansluitschema
2. De bedrijfsspanning aan de regelaar inschakelen. Op de display van het ruimte-apparaat moet een weergave verschijnen. Als dit niet zo is, kan dit de volgende oorzaken hebben:
 - de regelaar heeft geen netspanning
 - de bedrading naar de regelaar is onderbroken
 - het ruimte-apparaat is niet correct ingeklikt in de sokkel



Basisinformatie voor de bediening





Zie de handleiding voor bediening

Instellingen voor de eindgebruiker

Zie de handleiding voor bediening

Instelling op het niveau «Verwarmingsspecialist»

De toetsen  en  gelijktijdig indrukken, tot de bedienregel **51** wordt weergegeven. Daardoor wordt het instelniveau "Vakman" vrijgegeven voor instellingen.

Daarna kunnen met de toetsen  en  de afzonderlijke bedienregels worden gekozen en de waarden worden ingesteld met de toetsen  of .

Regel	Functie, weergave	Af fabr.	Bereik	Invoer	Toelichting, aanwijzingen, tips
51	Apparatenadres	1	1...10	Een dubbele punt geeft aanvullend de status van de communicatie aan: <ul style="list-style-type: none"> dubbele punt knippert regelmatig = communicatie loopt geen dubbele punt aanwezig of niet knipperend = gereed voor communicatie
52	Apparatenidentificatie	Weergavefunctie			xx yyyy xx = identificatienummer van het apparaat yyyy = SW-versienummer
53	Programmeerblokkering bedienregels	0	0 / 1	0 = geen bedienblokkering 1 = Alle bedienregels zijn geblokkeerd tegen verstelling. Tijdelijke opheffing van de bedienblokkering: Toetsen  en  indrukken tot "  -  -  -" wordt weergegeven. De modificaties kunnen nu worden uitgevoerd, tot het deksel weer wordt gesloten. Duurzame opheffing van de bedienblokkering: De bedienblokkering eerst tijdelijk opheffen. Aansluitend daaraan de bedienregel 53 op 0 instellen
55	Functie Ingang (D3/D4)	1	1 / 2 / 3 / RL	1 = externe opnemer: Op de display wordt aanvullend zijn temperatuur weergegeven ( = geen opnemer aangesloten, functie inactief). 2 = extern contact: Omschakeling op gereduceerde temperatuur. In de display wordt aanvullend de actuele contacttoestand weergegeven (000 = contact gesloten,  = contact open). 3 = extern contact: Omschakeling van de vorstbeveiligings-temperatuur. Het tapwater wordt bovendien uitgeschakeld. In de display wordt aanvullend de actuele contacttoestand weergegeven (000 = contact gesloten,  = contact open). RL = niet geoorloofde instelling
56	Bedrijf met extern contact (S1)	000	000 / 	000 = de op de bedienregel 55 ingestelde functie (2 of 3) werkt bij gesloten contact  = de op de bedienregel 55 ingestelde functie (2 of 3) werkt bij open contact
57	Invloed externe ruimte-opnemer (QAW44)	50 %	0...100%	0 % = externe opnemer werkt voor 0 % (interne opnemer werkt voor 100 %) 50 % = externe opnemer werkt voor 50 % (interne opnemer werkt voor 50 %) 100 % = externe opnemer werkt voor 100 % (interne opnemer werkt voor 0 %)
58	Weergave van de gewenste waarde	Ab5	Ab5 / rEL	De gewenste ruimtetemperatuurwaarden kunnen absoluut of relatief worden ingevoerd en weergegeven. Ab5 = absoluut; b.v. 20.5 °C rEL = relatief; b.v. + 0.5 °C

Afsluitende werkzaamheden

- De instellingen noteren in deze handleiding. De handleiding op een geschikte plaats bewaren
- De handleiding voor bediening in het apparaat schuiven

Maatschets

Zie de verpakking van het apparaat